



Avantco Ice Machines

Item #: 194KMCF430LA Project: \_\_\_\_\_

Qty: \_\_\_\_\_ Date: \_\_\_\_\_ Approval: \_\_\_\_\_

## Avantco Ice KMC-F-430-LA 30" Air Cooled Modular Full Cube Ice Machine with Bin - 397 lb.

Item #194KMCF430LA



### Technical Data

Width	30 Inches
Depth	24 3/8 Inches
Height	22 3/8 Inches
Bin Width	30 Inches
Bin Depth	34 Inches
Bin Height	51 Inches
Phase	1 Phase
Voltage	115 Volts
24 Hour Ice Yield	397 Pounds
Bin Storage Capacity	536 lb.

### Features

- Makes up to 397 lb. of full cube ice per day
- Durable roto plastic finish exteriors with polyethylene interiors
- Digital controller allows user to quickly identify issues
- Bright LED lights illuminate the ice bin
- Kit includes ice machine, ice bin, and ice scoop

### Certifications



ETL Sanitation



ETL US & Canada



3/4" Water Connection



5-15P

## Technical Data

Color	Silver
Condenser Type	Air Cooled
Features	LED Lighting
Ice Type	Full Size Cubes
Installation Type	Freestanding
Interior Material	Polyethylene
Material	Plastic
Plug Type	NEMA 5-15P
Refrigerant Type	R-290
Type	Ice Machines with Bins

## Plan View

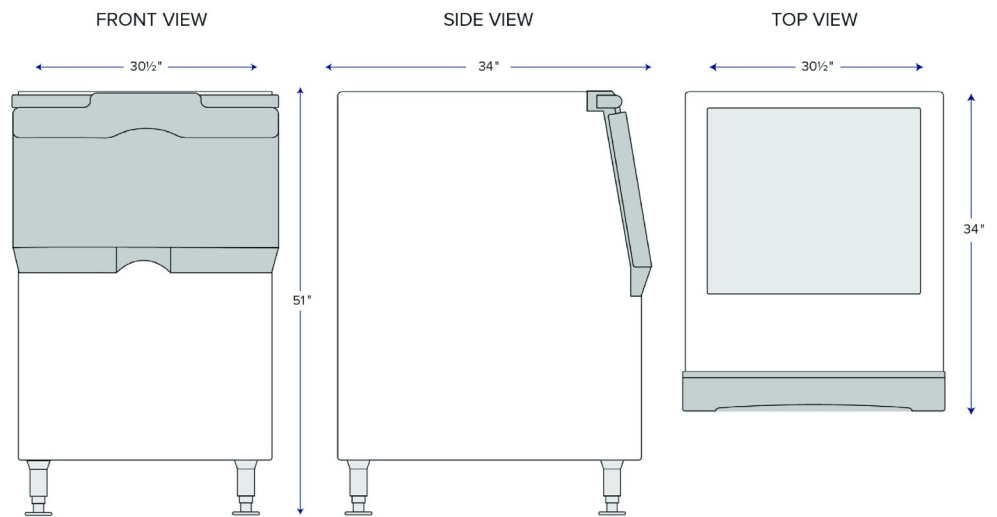
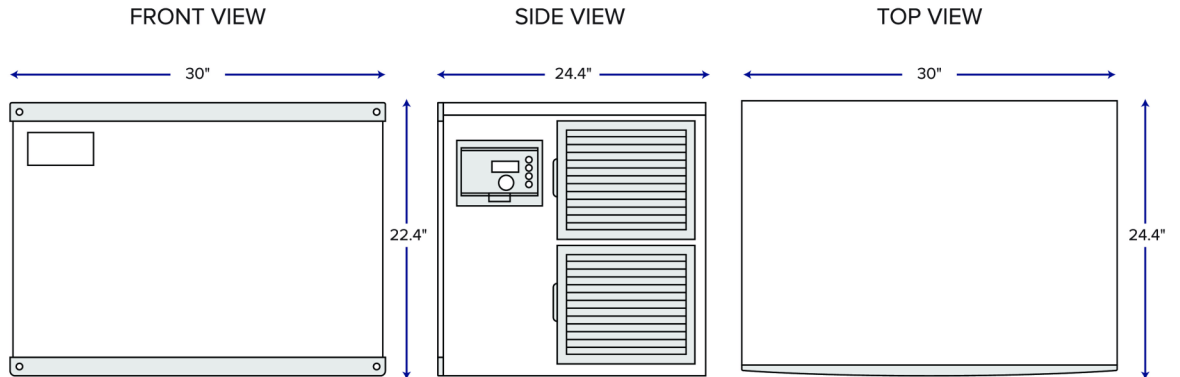



## Notes & Details

Make sure you've always got plenty of fresh ice on hand with the Avantco Ice KMC-F-430-LA 30" air cooled modular full cube ice machine with bin! Capable of producing up to 397 lb. of full cube ice per day, you'll always have plenty of ice to serve on demand at your restaurant, bar, or cafe. An included ice bin holds an impressive 536 lb. of ice, making it ideal for busy establishments that can not afford long periods of down-time while ice is being made. The ice bin features bright LED lights and a durable roto plastic exterior with a polyethylene interior. Also included is an ice scoop, a scoop holder ledge just inside the door where the ice scoop leans, and a hook to hang it on for easy storage.

For ease of maintenance, a built-in diagnostic system will identify problems that your ice machine may be having and will display the issue on the digital controller so it can be repaired accordingly. This easy-to-use controller can also be used to monitor the current stage of ice production that your machine is in. It allows you to adjust the bridge thickness up or down to maximize your harvest into individual cubes of ice, rather than full sheets. It also initiates the cleaning cycle and displays what stage of the cycle you're in.

The ice machine is constructed of durable roto plastic finish with a polyethylene interior to last in the busiest of commercial environments. A nickel plated evaporator and removable air filter make for quick and simple cleaning and maintenance. With (4) 6" adjustable legs, you can level your machine on uneven surfaces and have plenty of room to clean under it. This ice machine also comes with pre-drilled holes on the back of the unit to mount your OceanLoch water filter (sold separately) to the machine to ensure you are serving the cleanest and freshest ice possible. It also uses R290 refrigerant. Designed for side-breathing and rear exhaust, you can avoid hot air being blown outward into your kitchen or service area. This unit requires a 115V electrical connection for operation.

### **Kit Includes:**

- Avantco Ice KMC-F-430-LA 30" air cooled modular full cube ice machine - 397 lb.
- Avantco Ice BIN54030 30" ice storage bin with plastic exterior - 536 lb.
- Sanitary ice scoop

**⚠ WARNING:** This product can expose you to chemicals including lead, which are known to the State of California to cause cancer, birth defects, or other reproductive harm. For more information, go to [www.p65warnings.ca.gov](http://www.p65warnings.ca.gov).